

ROLLER CHAIN SPROCKETS AVAILABLE WITH MODEL DH CLUTCHES (continued)

| Sprocket Pitch | | Model 30-DH | | Model 35-DH | | Model 40-DH | | Model 45-DH | |
|----------------|-------|-------------|------------|-------------|------------|-------------|------------|-------------|------------|
| ASA # | Pitch | Min. Teeth | Max. Teeth | Min. Teeth | Max. Teeth | Min. Teeth | Max. Teeth | Min. Teeth | Max. Teeth |
| ASA 50 | 5/8 | 45 | 95 | | | | | | |
| ASA 50-2 | 5/8 | 48 | 95 | | | | | | |
| ASA 60 | 3/4 | 38 | 84 | 45 | 95 | | | | |
| ASA 60-2 | 3/4 | 42 | 84 | 48 | 95 | | | | |
| ASA 80 | 1 | 30 | 60 | 34 | 72 | 48 | 84 | | |
| ASA 80-2 | 1 | 32 | 60 | 38 | 72 | 54 | 84 | | |
| ASA 100 | 1 1/4 | 23 | 48 | 27 | 60 | 40 | 70 | 54 | 72 |
| ASA 100-2 | 1 1/4 | 27 | 48 | 32 | 60 | 42 | 70 | 54 | 72 |
| ASA 120 | 1 1/2 | 20 | 42 | 23 | 48 | 34 | 54 | 42 | 70 |
| ASA 140 | 1 3/4 | | | | | 30 | 48 | 36 | 60 |
| ASA 160 | 2 | | | | | | | 32 | 48 |

Parts List

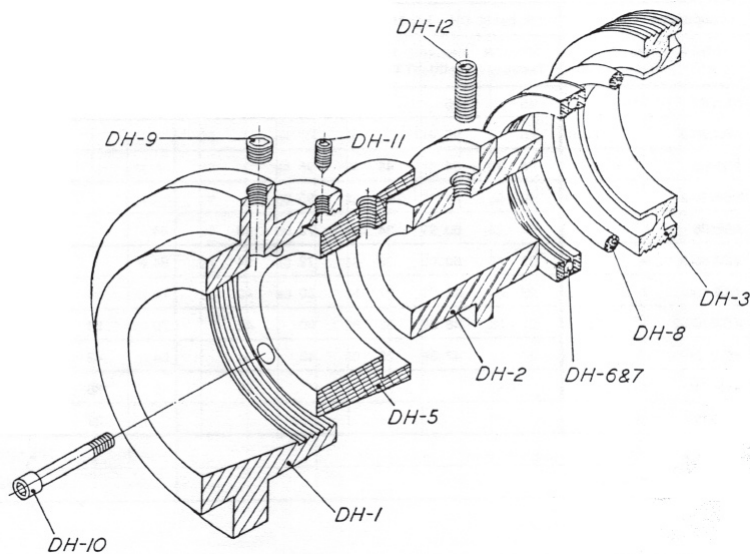

- 1 Housing
- 2 Thrust head
- 3 Adjustment nut
- 5 Friction cone
- 6 & 7 Thrust bearing assembly
- 8 Pressure ring
- 9 Pipe plug
- 10 Cap screws-4 (On size 40 and 45 only)
- 11 Conepoint screw
- 12 Setscrews-2

When requesting parts or additional information, please reference the clutch size.
For part #1, housing, provide as much detailed information as possible.