

ROLLER CHAIN SPROCKETS AVAILABLE WITH MODEL I CLUTCHES (continued)

Sprocket Pitch		Model 30-I		Model 35-I		Model 40-I		Model 45-I	
ASA #	Pitch	Min. Teeth	Max. Teeth	Min. Teeth	Max. Teeth	Min. Teeth	Max. Teeth	Min. Teeth	Max. Teeth
ASA 50	5/8	34	95						
ASA 50-2	5/8	34	95						
ASA 60	3/4	28	84	34	95				
ASA 60-2	3/4	28	84	34	95				
ASA 80	1	21	60	26	72	34	84		
ASA 80-2	1	21	60	26	72	34	84		
ASA 100	1 1/4	18	48	21	60	27	70	34	72
ASA 100-2	1 1/4	18	48	21	60	27	70	34	72
ASA 120	1 1/2	16	42	18	48	22	54	28	70
ASA 140	1 3/4					21	48	25	60
ASA 160	2							22	48

Parts List

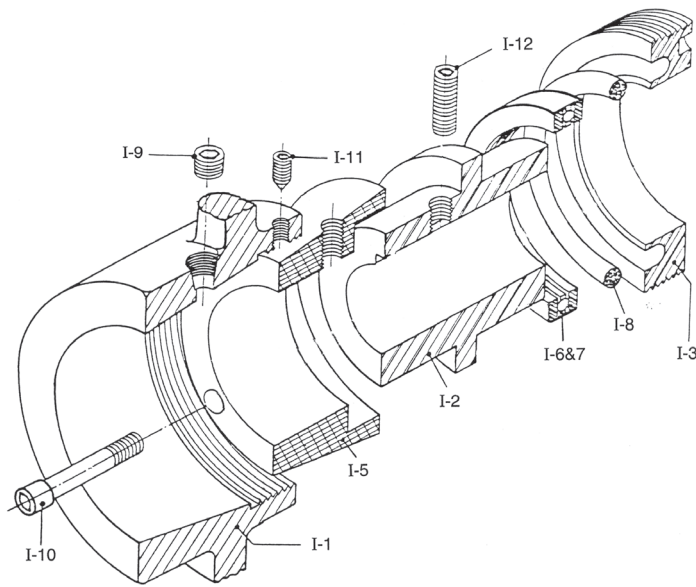

- 1 Housing
- 2 Thrust head
- 3 Adjustment nut
- 5 Friction cone
- 6 & 7 Thrust bearing assembly
- 8 Pressure ring
- 9 Pipe plug
- 10 Cap screws-4 (On size 40 and 45 only)
- 11 Conepoint screw
- 12 Setscrews-2

When requesting parts or additional information, please reference the clutch size. For part #1, housing, provide as much detailed information as possible.